

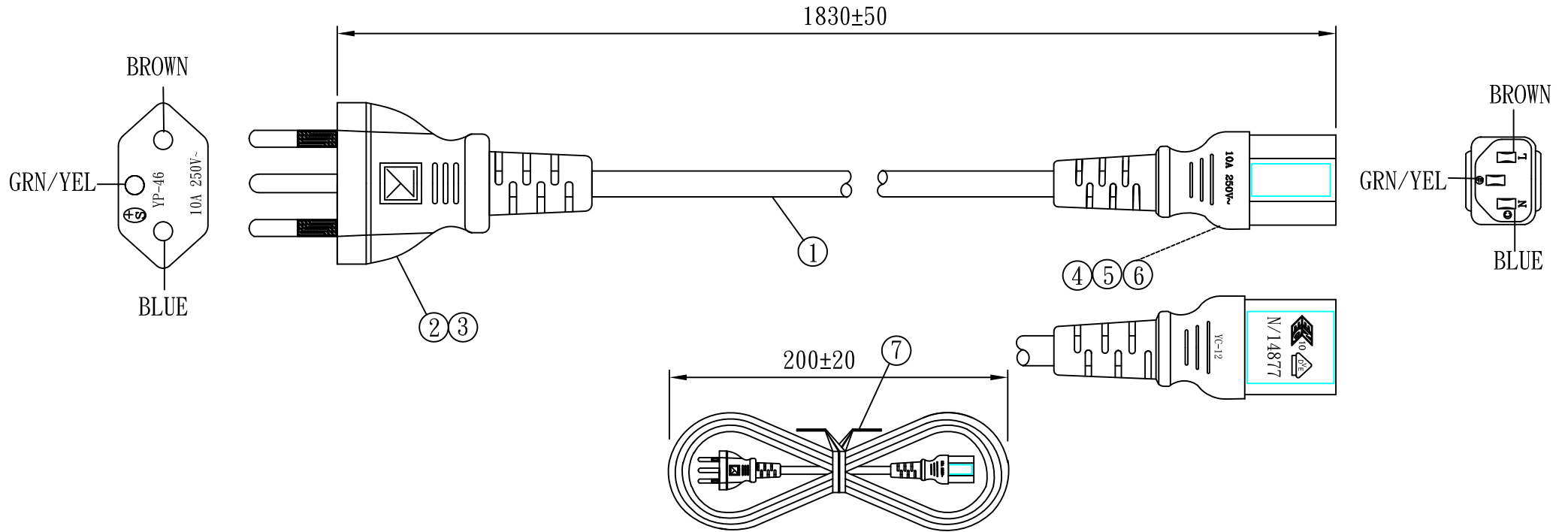

No advice if add any approval marks on this POWER CORD



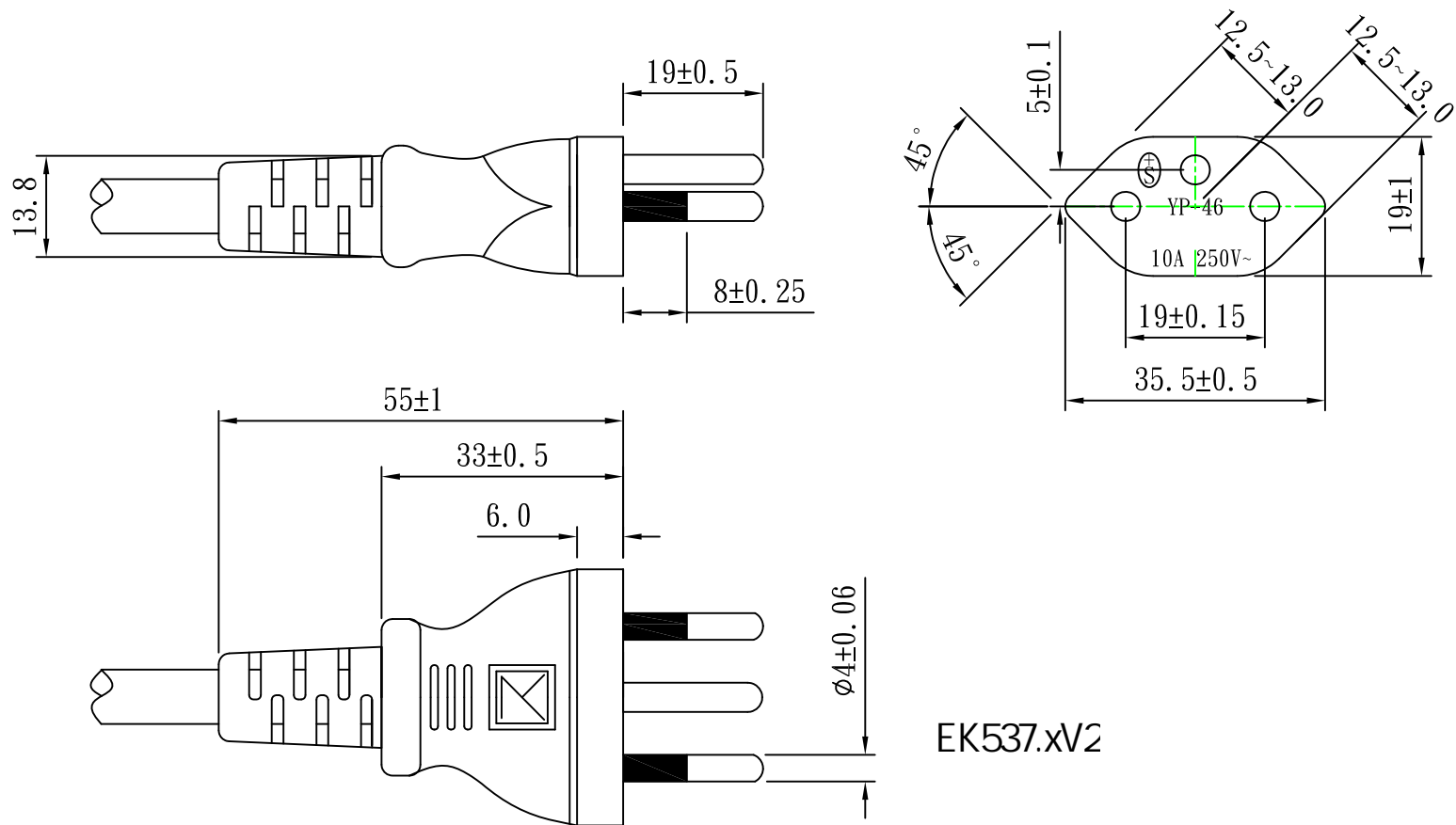

NO.	SPECIFICATION	Q' TY	REMARK
1	H05VV-F 0.75/3C BLACK	1PC	
2	YP-46 PVC PLASTIC:50P BLACK	18g/PC	
3	SWITZERLAND FRAME:P97005P BLACK	1PC	
4	YC-12 PVC PLASTIC:50P BLACK	18g/PC	
5	"U" TER:97740	3PCS	
6	YC-12 INNER BODY	1PC	
7	MINI TIE=130mm BLACK	1PC	

Tolerance >0±0.30 >1.0±0.50 >10.0±1.0 >20.0±2.0 Angle:	Approved		Date		EK537.xV2				
	Checked		Date						
	Drawn		Date		Customer				
	Cat. No.				P/N.				
	Drawing No.			Rev.	B	Material	P.V.C	Unit	mm
						HEFT(g)			



EK537.xv2

Tolerance >0±0.30 >1.0±0.50 >10.0±1.0 >20.0±2.0 Angle: ±1°	Approved		Date					
	Checked		Date					
	Drawn		Date		Customer			
	Cat. No.	YP-46			P/N.			
	Drawing No.		Rev.	B	Material	P. V. C	Unit	mm
					Scale			 



N/14877

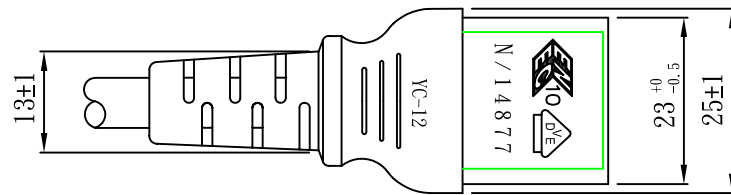
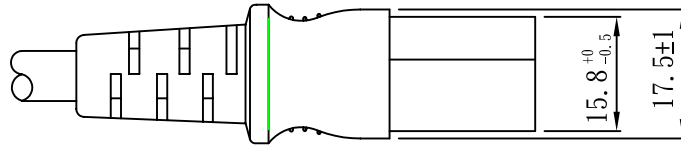
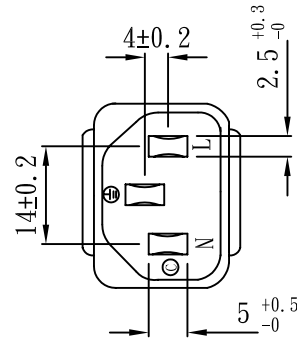
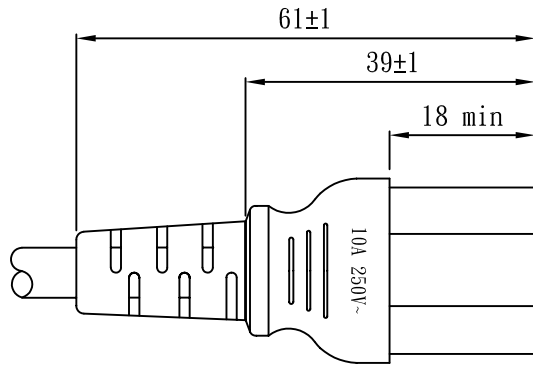

TOLERANCE >0±0.30 >1.0±0.50 >10.0±1.0 >20.0±2.0 Angle: ±1°	APPROVED		DATE		EK537.xv2				
	CHECKED		DATE						
	DRAWN		DATE		CUSTOMER				
	TYPE	YC-12(VDE)			P/N				
	DRAWING NO.		REV	B	SCALE	P. V. C	UNIT	mm	
					1:1				